

proxima®

Desktop Projector

Model

DP6850 / DP6850+

USER'S GUIDE

Thank you for purchasing the PROXIMA Desktop projector. Please read this user's manual thoroughly to ensure correct usage through understanding. After reading, store this instruction manual in a safe place for future reference.

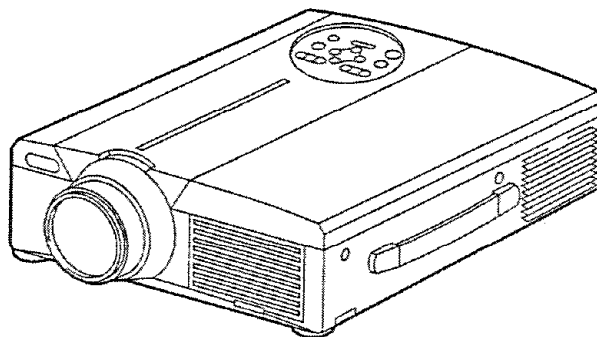

Outline

The DP6850 and DP6850+ are bright enough to fill a room and versatile enough to fulfill your demanding needs. Their superb image quality and advanced video capabilities make them dependable tools for classrooms and meeting rooms.

Features

- (1) Digital keystone correction makes it easy to project a square image and increases placement possibilities.
- (2) Bright images make it ideal for conference rooms and classrooms
- (3) True XGA (1024 x 768) resolution and Fit-to-View® display of VGA (640 x 480) through SXGA (1280 x 1024) supports full screen images from PCs and Macintosh computers
- (4) Flexible connectivity with ports for up to two computers and USB mouse
- (5) High-quality video performance with picture-in-picture and support for most video formats
- (6) Motorized zoom and focus offers flexibility in projector placement, while digital zoom offers

Contents

Page

Before Use.....	3
Checking the package Contents.....	8
Names and functions of each part.....	8
Installation	12
Basic operations	13
Adjustments and functions.....	17
Connection to the video signal terminals	22
Connection to the RGB signal terminal	22
Connecting to the USB cable.....	25
Connection to the CONTROL signal terminal	26
Example of system setup.....	31
Cleaning the air filter.....	31
Lamp	32
Message table.....	32
Troubleshooting.....	33
Specifications.....	34
About the warranty and after-service	35

About Trademarks

- VGA and XGA are trademarks of IBM (International Business Machines Corporation).
 - Macintosh is a registered trademark of Apple Computer Corporation of the U.S.
 - VESA and SVGA are trademarks or registered trademarks of Video Electronics Standards association.
 - Windows95 and Windows98 are registered trademarks of Microsoft Corporation in the U.S. and other countries.
- Carefully observe the trademarks and registered trademarks of all companies, even when not mentioned.

FOR THE CUSTOMERS IN U.K

THIS PRODUCT IS SUPPLIED WITH A TWO PIN MAINS PLUG FOR USE IN MAINLAND EUROPE.
FOR THE U.K PLEASE REFER TO THE NOTES ON THIS PAGE.

IMPORTANT FOR UNITED KINGDOM

WORDING FOR CLASS I EQUIPMENT INSTRUCTION BOOKS AND LABELS

The mains lead on this equipment is supplied with a moulded plug incorporating a fuse, the value of which is indicated on the pin face of the plug. Should the fuse need to be replaced, an ASTA or BSI approved BS 1362 fuse must be used of the same rating. If the fuse cover is detachable never use the plug with the cover omitted. If a replacement fuse cover is required, ensure it is of the same colour as that visible on the pin face of the plug. Fuse covers are available from your dealer.

DO NOT cut off the mains plug from this equipment. If the plug fitted is not suitable for the power points in your home or the cable is too short to reach a power point, then obtain an appropriate safety approved extension lead or consult your dealer.

Should it be necessary to change the mains plugs, this must be carried out by a competent person, preferably a qualified electrician.

If there is no alternative to cutting off the mains plug, ensure that you dispose of it immediately, having first removed the fuse, to avoid a possible shock hazard by inadvertent connection to the mains supply.

WARNING: THIS EQUIPMENT MUST BE EARTHED **IMPORTANT:**

The wires in the mains lead are coloured in accordance with the following code:
Green and Yellow = Earth, Blue = Neutral, Brown = Live.

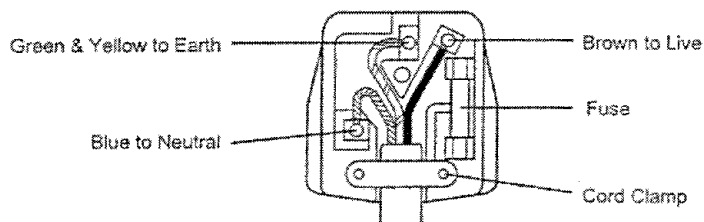

As these colours may not correspond with the coloured markings identifying the terminals in your plug, proceed as follows:

The wire which is coloured Green and Yellow must be connected to the terminal in the plug which is marked with the letter E or by the earth symbol \oplus or coloured Green or Green and Yellow.

The wire coloured Blue must be connected to the terminal marked with the letter N or coloured BLUE or BLACK. The wire coloured BROWN must be connected to the terminal marked with the letter L or coloured BROWN or RED.

WARNING: This equipment has been tested and found to comply with the limits for a Class A digital device, pursuant to Part 15 of the FCC Rules. These limits are designed to provide reasonable protection against harmful interference when the equipment is operated in a commercial environment. This equipment generates, uses, and can radiate radio frequency energy and, if not installed and used in accordance with the instruction manual, may cause harmful interference to radio communications. Operation of this equipment in a residential area is likely to cause harmful interference in which case the user will be required to correct the interference at his own expense.

Instructions to Users:

This equipment complies with the requirements of FCC (Federal Communication Commission) Class A equipments provided that following conditions are met.

(1) Video signal cables:

Double shielded coaxial cables (so called FCC shield cable) must be used and the outer shield must be connected to the ground. Or, if normal coaxial cables are used, the cables must be enclosed in metal pipes or similar way to reduce the interference noise radiation.

(2) Power cord:

Shielded power cord must be used. The outer shield must be connected to the ground.

(3) Video inputs:

The input signal amplitude must no exceed the specified level.

Before Use

<Before Using>

About the Symbols Various symbols are used in this instruction manual and on the product itself to ensure correct usage, to prevent danger to the user and others, and to prevent property damage. The meanings of these symbols are described below. It is important that you read these descriptions thoroughly and fully understand the contents.



Warning

This symbol indicates information that, if ignored, could possibly result in personal injury or even death due to incorrect handling.



Caution

This symbol indicates information that, if ignored, could result possibly in personal injury or physical damage due to incorrect handling.

Typical Symbols



This symbol indicates an additional warning (including cautions). An illustration is provided to clarify the contents (the illustration to the left indicates danger of electrical shock).



This symbol indicates a prohibited action. The contents will be clearly indicated in an illustration or nearby (the symbol to the left indicates that disassembly is prohibited).



This symbol indicates a compulsory action. The contents will be clearly indicated in an illustration or nearby (the symbol to the left indicates that the power plug should be disconnected from the power outlet).

[Safety Precaution]

Warning

■ If a problem should occur.

- If smoke or a strange odor arise, continued use could result in fire or electrical shock. In such case, immediately turn off the power switch and then disconnect the power plug from the power outlet. After making sure that the smoke or odor has stopped, contact your dealer for repairs. Never attempt to make repairs yourself because this is dangerous.

- Do not use this projector if there is no image or sound, or if the sound is distorted. Continued use could result in fire or electrical shock.



Disconnect the plug from the power outlet.

In such case, immediately turn off the power switch, disconnect the power plug from the power outlet and contact your dealer.

- If water should enter the inside of this projector, immediately turn off the power switch, disconnect the power plug from the power outlet and contact your dealer.

■ Do not install on an unstable surface.

- Do not install this projector on an unstable surface such as a wobbly stand or incline because this could result in the projector falling and causing injury.



■ Do not open the cabinet.

- Never open the cabinet. There is high voltage inside which can cause electrical shock. Contact your dealer for internal inspection, adjustment and repair.



Do not disassemble.



Electric shock hazard.

■ Do not modify.

- Do not modify this projector because this could result in fire or electrical shock.



Do not disassemble.

■ Do not use in the bathroom.

- Do not use this projector in the bathroom because this could result in fire or electrical shock.



Do not use near water.

■ Do not insert foreign objects.

- Do not insert metal objects through the ventilation openings, etc., of this projector or drop such objects inside because this could result in fire or electrical shock.



- If a foreign object should enter this projector, immediately turn off the power switch, disconnect the power plug from the power outlet and contact your dealer.



Disconnect the plug from the power outlet.

Continued use could result in fire or electrical shock. Use special caution in households where children are present.

■ Do not look through the lens when the lamp is on.



Never look through the lens when the lamp is on. The powerful light could adversely affect vision. Use special caution in households where children are present.

■ Avoid shock or impact on the projector.

- If the projector should fall, resulting in damage to the cabinet, immediately turn off the power switch, disconnect the power plug from the power outlet and contact your dealer. Continued use could result in fire or electrical shock.



Disconnect the plug from the power outlet.

■ Do not place this projector in a container containing liquid.

- Do not place flower vases, flower pots, cups, cosmetics, liquids such as water, etc., on top of this projector. Spillage could result in fire or electrical shock.



■ Use only the indicated power supply.

- Use only the indicated power supply. The use of any other power supply could result in fire or electrical shock.



Warning

■ Handle the power cord with care.

• Do not damage, cut, process or strongly twist the power cord. Placing heavy objects on the power cord, heating or strongly pulling the power cord can result in damage as well as fire or electrical shock.

- Pulling on the power cord
- Placing heavy objects on the power cord
- Damaging the cord
- Placing near heaters



• Do not position the power cord under the projector. This can damage the power cord and cause fire or electrical shock. Also, do not place a spread, cover, etc., over the power cord because this could result in the inadvertent placing of heavy objects on the concealed power cord.

• If the power cord is damaged (exposed or broken core wires, etc.), contact your dealer for replacement; otherwise, fire or electrical shock could result.



• Make sure there is no dust, etc., on the power plug and insert a knife blade to make sure that there is no looseness.

■ Do not allow the laser beam to enter the eyes.

• This remote control is equipped with a laser pointer and a laser beam is emitted from the laser outlet. Do not look directly into the laser beam outlet or direct the laser beam at other people.

Vision can be impaired if the laser beam enters the eyes. Use special caution where children are present.

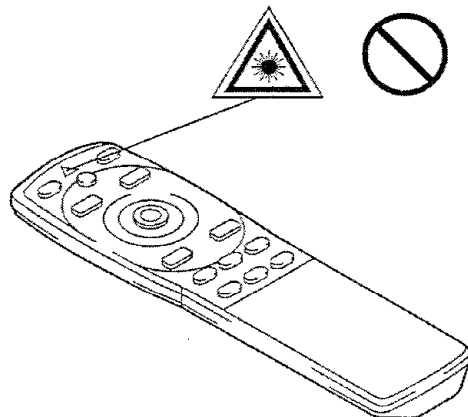

■ High temperatures are generated when the lamp is lit, so do not place objects in front of the lens.

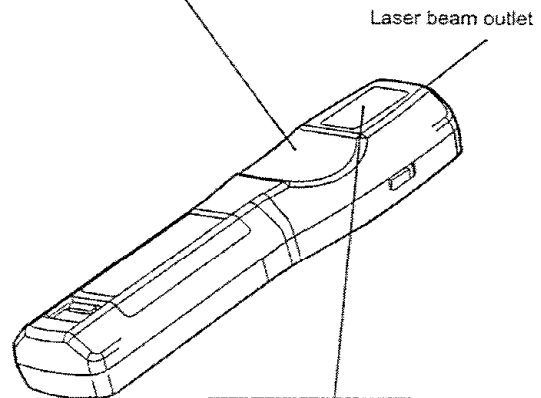

AVOID EXPOSURE- LASER RADIATION IS EMITTED FROM THIS APERTURE

Caution

■ Do not sit or place heavy objects on this projector.

• Do not sit on this projector.

This could result in overturning, leading to damage or personal injury. Use special caution in households where children are present.



• Do not place heavy objects on this projector.

Placing heavy objects on this projector could result in loss of balance or falling and cause personal injury.

■ Do not block the ventilation openings. Do not block the ventilation openings of this projector.

Blocking ventilation could lead to internal overheating which could result in fire. Do not place this projector on its side during use or push it into a small, poorly ventilated location. Do not place this projector on a carpet or bedding or cover it with a table cloth, etc. Also, when installing this projector, make sure the ventilation openings are at least 30cm from the wall.



■ Care and maintenance.

For safety purposes, disconnect the power plug from the power outlet before starting the care and maintenance of this projector.



Disconnect the plug from the power outlet.

■ Battery usage.

• Use only the specified batteries with this projector. Do not mix old and new batteries because this could result in fire or personal injury due to battery cracking or leakage.



• Make sure the plus and minus terminals are correctly aligned when loading the batteries. Incorrect loading could result in personal injury or contamination of the surroundings due to battery cracking or leakage.



■ Clean the projector interior once every two years.

Request your dealer to clean the interior of the projector approximately every two years. Accumulations of dust inside the projector can result in fire or malfunction if not cleaned for an extended period. This cleaning is more effective if performed before every humid periods such as rainy season, etc. Ask your dealer for details about internal cleaning.



■ Avoid installation in humid or dusty locations.

• Do not install this projector in a humid or dusty location. This could result in fire or electrical shock.



• Avoid installation near the kitchen, a humidifier or other locations where there is oily smoke or humidity. This could result in fire or electrical shock.

■ Use the caster brakes.

When installing this projector on a stand with casters, use the caster brakes to prevent the stand moving or overturning and causing personal injury.



■ Do not handle the power cord roughly.

• Keep the power cord away from heaters because the heat could melt the power cord and cause fire or electrical shock.

• Do not touch the power plug with wet hands because this could result in electrical shock.



• When disconnecting the power plug, do not pull on the power cord. This could damage the power cord and cause fire or electrical shock. Always grip the plug when disconnecting.



Caution

■ When the projector is not to be used for an extended period.

For safety purposes when the projector is not to be used for an extended period because of travel, etc., always disconnect the power plug from the power outlet. Also close the lens cover to prevent the lens surface being scratched.



Disconnect the plug from the power outlet.

■ Moving the projector.

- When moving the projector, be sure to replace lens cap, disconnect the power plug from the power outlet and disconnect all external connections. Failure to do this could damage the power cord and cause fire or electrical shock.



Disconnect the plug from the power outlet.

Avoid any impact or shock to the projector because this could result in malfunction.

- When moving this projector outdoors, protect it from wetting due to rain, etc. If the projector should become wet, dry it thoroughly before further use. Continued use while wet could result in fire or electrical shock.



[General Cautions]

■ Avoid excessively hot locations.

Do not place this projector in direct sunlight or near a hot object such as a stove, etc., because the heat could have adverse influence on the cabinet and other parts.



■ Sound volume.

Set the volume at a suitable level to avoid bothering other people. It is also better to keep the volume level low and close the windows at night to protect the neighborhood environment.

■ Lens care

Use commercially available lens tissue to clean the lens (used to clean cameras, eyeglasses, etc.). Be careful not to scratch the lens with hard objects.



■ Cabinet care.

- The cabinet is made of plastic and discoloration or paint peeling can occur if wiped with a solvent such as benzine, thinner, etc.
- Before using chemical wipes, be sure to read and observe the instructions.
- Do not spray volatile substances such as insect repellent on the cabinet. Also, do not allow long-term close contact with rubber or vinyl products because this could result in discoloration, peeling paint, etc.
- Use a soft cloth to clean the cabinet and operation panel. When excessively soiled, dilute a neutral detergent in water, wet and wring out the cloth and afterward wipe with a dry cloth. Do not apply undiluted detergent directly to the projector.

■ Extended usage.

When using this projector for an extended period, stop periodically to rest the eyes to prevent eye fatigue.

Checking the package Contents

Make sure all of the following items are included in the package. If anything is missing, please contact your dealer.

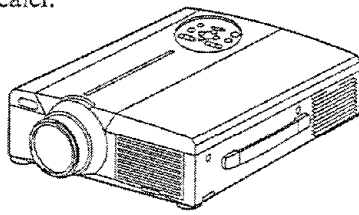

Projector unit

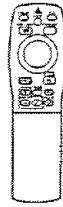

Remote control

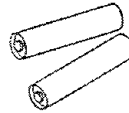

Remote control Batteries

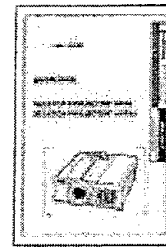

User's Guide (this document)



Registration Card



Power Cord x 3
110V-US
220-UK, Europe

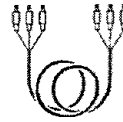

3-Conductor Video/Audio Cable

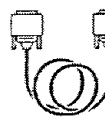

RGB Cable (15-15 pin M/M)



Mac adapter with dip switch

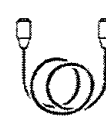

S-Video Cable (S-Video mini Din4-pin)



Stereo mini jack cable

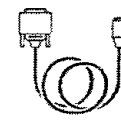

Mouse cable x 3

Names and functions of each part

Main unit

ZOOM button
Used to adjust the size of the image. (Refer to page 13.)

MUTE button
This button turns the sound on and off. Press once to turn the sound off, then press again to turn the sound back on.

STANDBY / ON button
Press this button to turn the power on and off. When turned off, the projector enters standby status. Refer to page 13 - 14 for details.

LAMP indicator
Lights or flashes when the temperature inside the projector increases or the lamp does not light. Refer to page 33 for details.

POWER indicator
This indicator lights or blinks during standby and during operation. Refer to page 33 for details.

Remote control I/R receiver

Lens

Lens cap

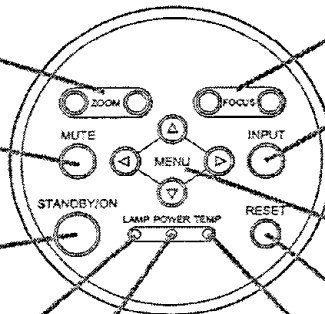

FOCUS button
Used to adjust the focus of the image on the screen. (Refer to page 13.)

INPUT button
Press this button to switch the input. The input changes in the following sequence each time this button is pressed.

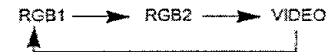

MENU button
Displays the image menu. Refer to page 17 - 21 for details.

RESET button
Used to reset the initial settings. Refer to page 10, 17, 25, 26 for details.

TEMP indicator
Blinks when the fan malfunctions. Refer to page 33 for details.

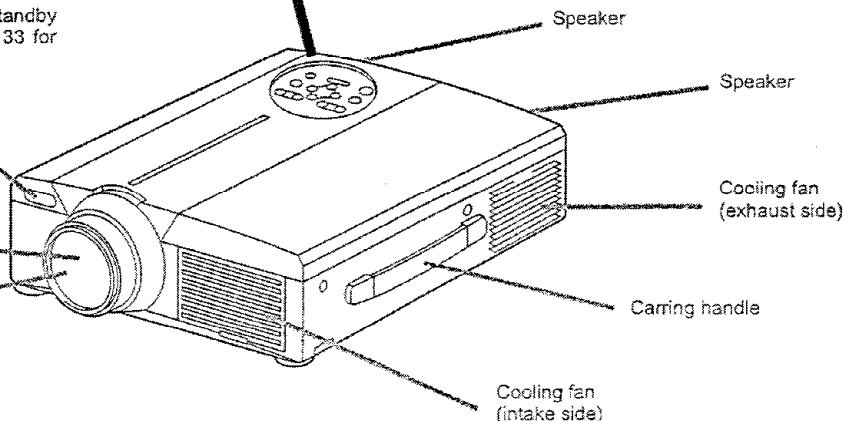

- Use the remote control in front of the remote control photoreceptor at a distance of about 5 m or less and an angle of 30 degrees to the left or right of the center.

Names and functions of each part (continued)

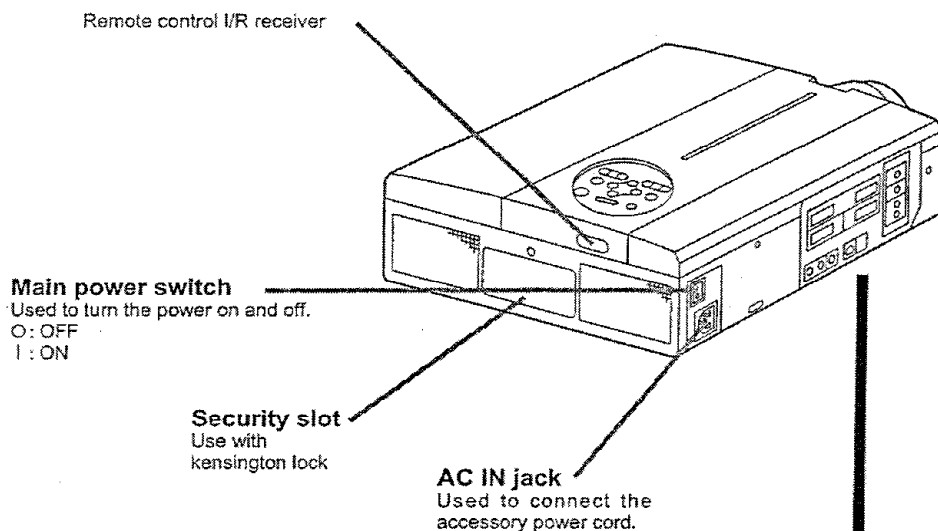

⚠ Caution **Connecting to the AC IN jack**
Make sure the accessory power cord is plugged into the AC IN jack as far as it will go. Incomplete connection can result in fire or electrical shock.

VIDEO IN jack
S-VIDEO IN jack
Mini DIN 4-pin connector
VIDEO IN jack
RCA jack
AUDIO L/R IN jack
RCA jack

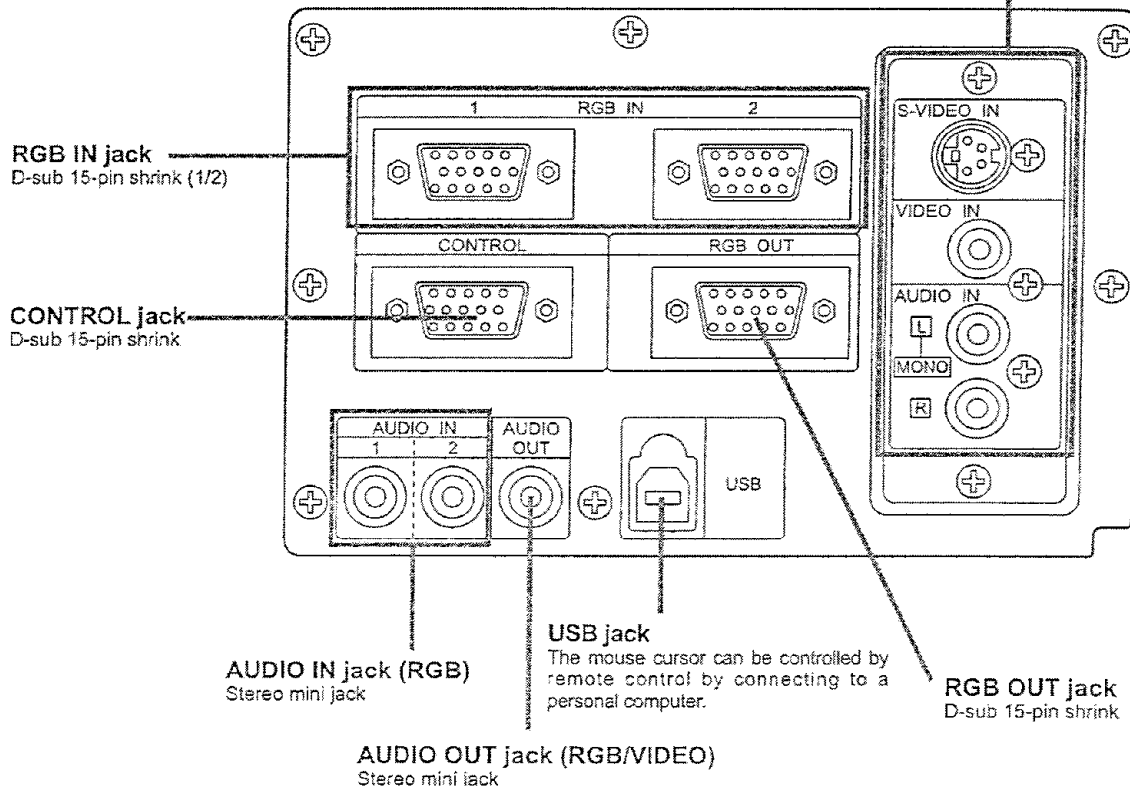

Names and functions of each part (continued)

Remote control transmitter

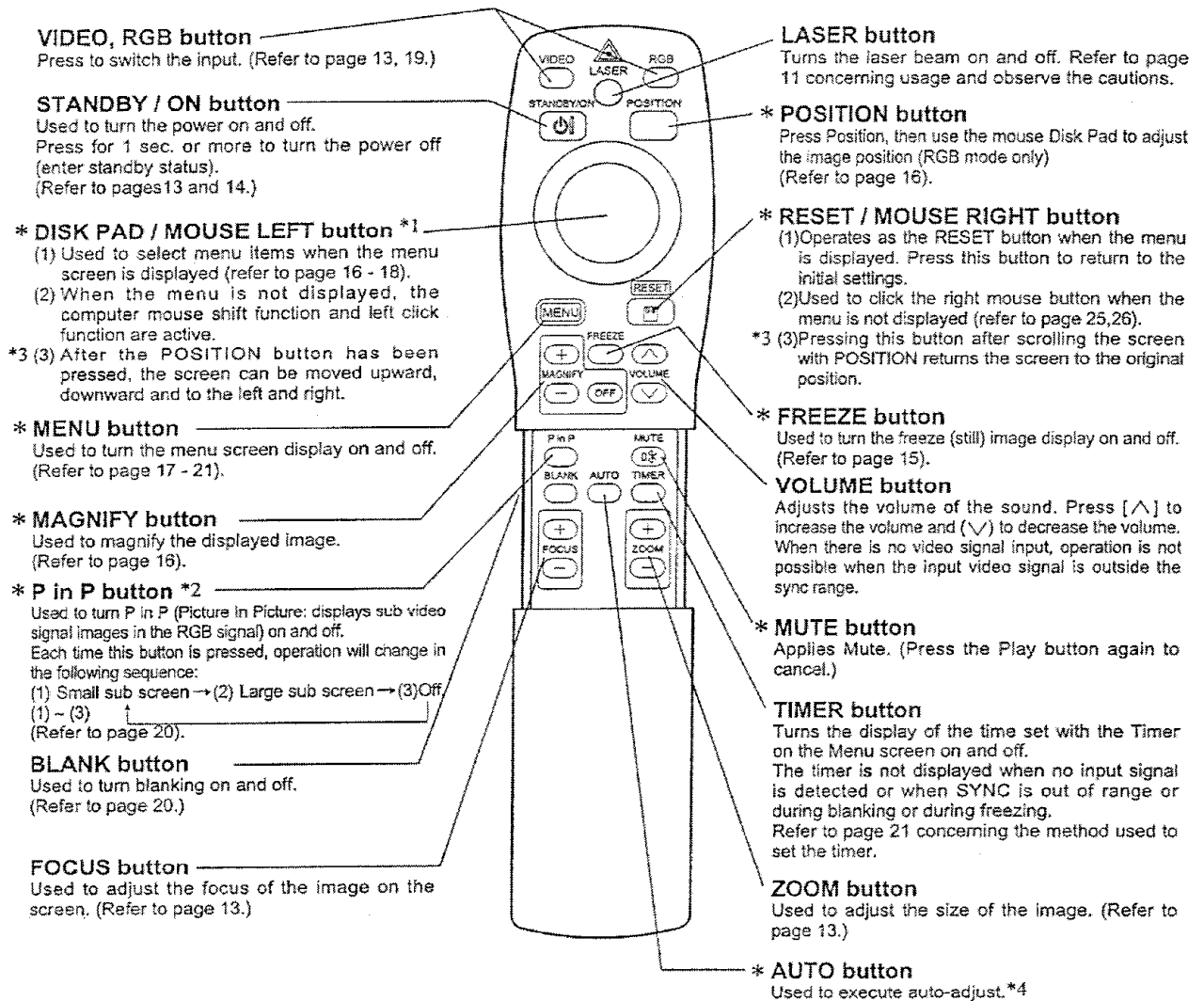

*These functions do not operate when initial screen message "NO INPUT IS DETECTED" or "SYNC IS OUT OF RANGE" is displayed.

*1 Disk Pad method of operation

- Move and select by tilting Disk Pad in the required direction.
- Press Disk Pad in to realize the function of the mouse left button.
- A mouse cable is necessary if a mouse is to be used.
(Refer to pages 26, 27.)

*2 P in P function

With the P in P function, signals are input to both RGB and VIDEO. This function operates only when the RGB signal has been selected. There is no display in the case of the no signal and when the RGB signal is outside the sync range.
When P in P is used, audio is automatically switched to video.
In P in P, audio input can be switched by pressing the VOL ^ and VOL v keys of the remote control, displaying the audio bar and moving DISK PAD left and right during the display.

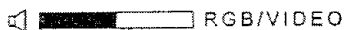

*3 POSITION icon

When the POSITION button is pressed, the moving display icon will appear at the bottom right of the screen.
While displaying the icon, you can operate POSITION.

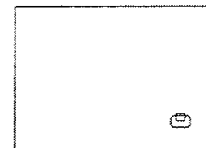

*4 Auto adjustment function

The projector automatically adjusts 4 items (V. POSIT, H. POSIT, H. PHASE, H. SIZE).
When you choose AUTO (move the cursor to the right from the manual operation position), the AUTO confirmation menu shown below is indicated.

Names and functions of each part (continued)

- Caution**
- Auto adjust can take up to 30 seconds.
 - Auto adjust may not operate correctly in some cases, depending on the computer connected and the signal.
 - Be sure to expand images to full screen size when displaying low resolution images.
 - After auto adjust, the image may be slightly dark in some cases due to automatic adjustment of the signal level.
 - Auto adjust can not execute when the initial display is "NO INPUT IS DETECTED" or "SYNC IS OUT OF RANGE" during FREEZE or MAGNIFY.
 - Auto Adjust is executed when the following operations are performed.
 1. When the type of input source signal is changed.
 2. When the Auto Adjust (AUTO) button is pressed.
 - The message AUTO IN PROGRESS will be displayed on the screen during automatic adjustment.
 - The screen may be disrupted during automatic adjustment but this is not a malfunction.
 - RGB1 or RGB2 only can be used as the input signal.
 - Auto Adjust can also be executed using the operation buttons of the main unit. Hold down the RESET button and press the input switch (INPUT) button.

Loading the batteries Loading AA batteries into the remote control.

- 1 Remove the battery cover.**
Push the knob while lifting up the battery cover.

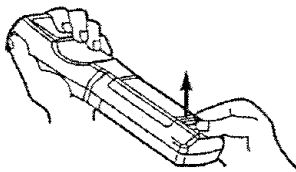

- 2 Loading the batteries.**
Make sure the plus and minus poles are correctly oriented.

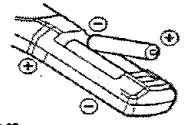

- 3 Close the battery cover.**

Caution Battery usage cautions

- Use only the specified batteries with this projector. Also, do not mix new and old batteries. This could cause in battery cracking or leakage, which could result in fire or personal injury.
- When loading the batteries, make sure the plus and minus poles are correctly oriented as indicated in the projector. Incorrect orientation could cause battery cracking or leakage, which could result in personal injury or pollution of the surrounding environment.

Caution Remote control usage cautions

- Do not drop the remote control or apply impact.
- Do not wet the remote control or place it on any wet object. Such actions could result in malfunction.
- When not to be used for an extended period, remove the batteries from the remote control.
- Replace the batteries when remote control operation becomes difficult.
- Do not place the remote control close to the cooling fan of the projector.
- Do not disassemble the remote control in case of malfunction. please bring it to the service station.

Warning

The laser pointer of the remote control is used as a pointer. Never look directly into the laser beam outlet or point the laser beam at other people. The laser beam can cause vision problems.

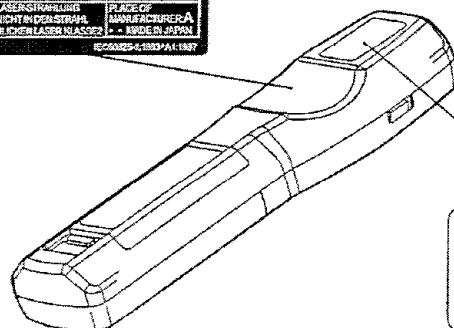

AVOID EXPOSURE- LASER RADIATION IS EMITTED FROM THIS APERTURE

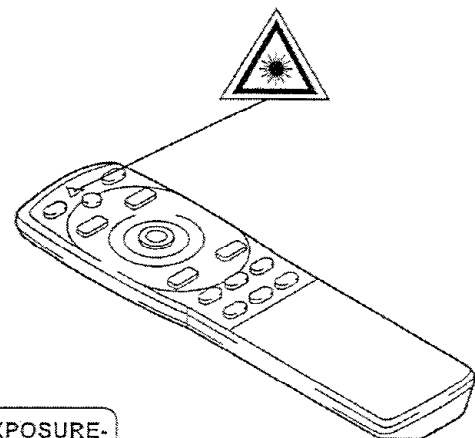

Installation

Typical LCD Projector and Screen Installation

Use the diagram below as reference to determine the screen size and projection distance.

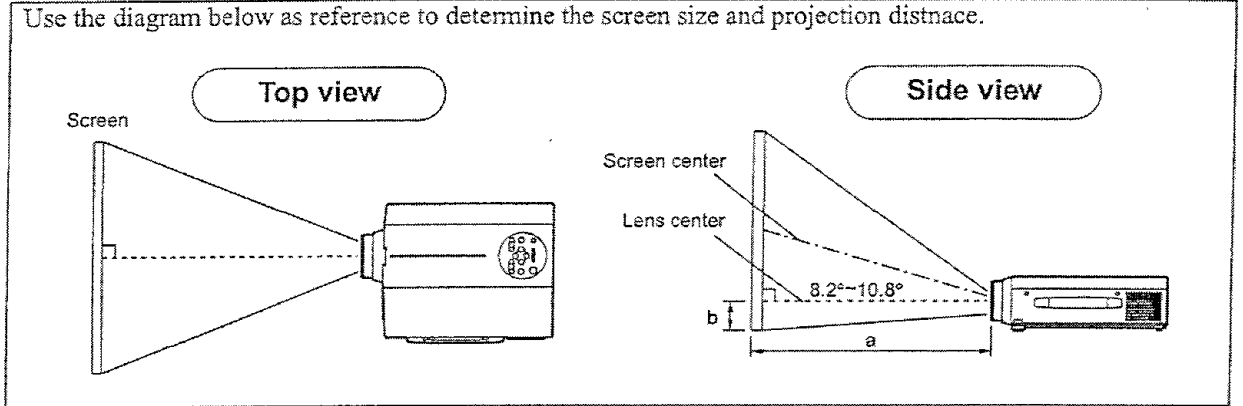

Diagonal screen size (inches)	a (inches)		b (inches)
	Minimum	Maximum	
40	55	73	1
60	85	114	2
80	114	151	2
100	144	191	3
120	176	231	3
150	220	282	4
200	291	386	6

a. Distance from the LCD projector to the screen
 b. Distance from the lens center to the bottom of the screen (a,b : +/-10%).

Caution

The LCD projector should normally be used level (the legs can point upward). Positioning the projector sideways, or with the lens pointing upward or downward can cause the internal temperature to rise, which could result in a malfunction.

The projection distances shown in the diagram to the left are for full size (1,024 x 768 dots).

Using the adjusters

Use the adjusters on the bottom to adjust the projection angle.

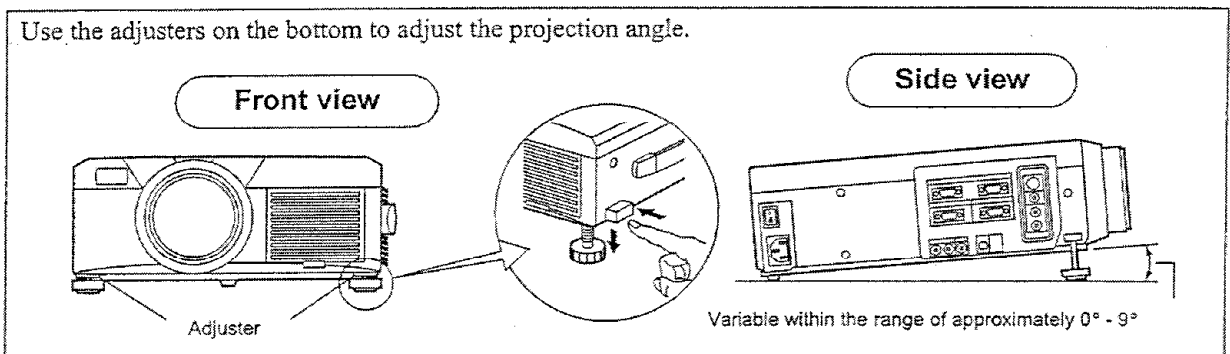

1. Lift up the projector and release the adjuster lock.
2. After adjusting the projection angle, firmly lock the adjusters.
3. Rotate the adjusters for fine adjustment.

Caution

- Do not release the locks unless the projector is being held; otherwise, the projector could overturn or the fingers could get caught and cause personal injury.
- Do not force the adjusters to rotate. This could damage the adjusters or cause the lock to fail.
- Lock the adjusters firmly. If the lock is difficult to operate, change the angle slightly and try again.

Basic operations

To project

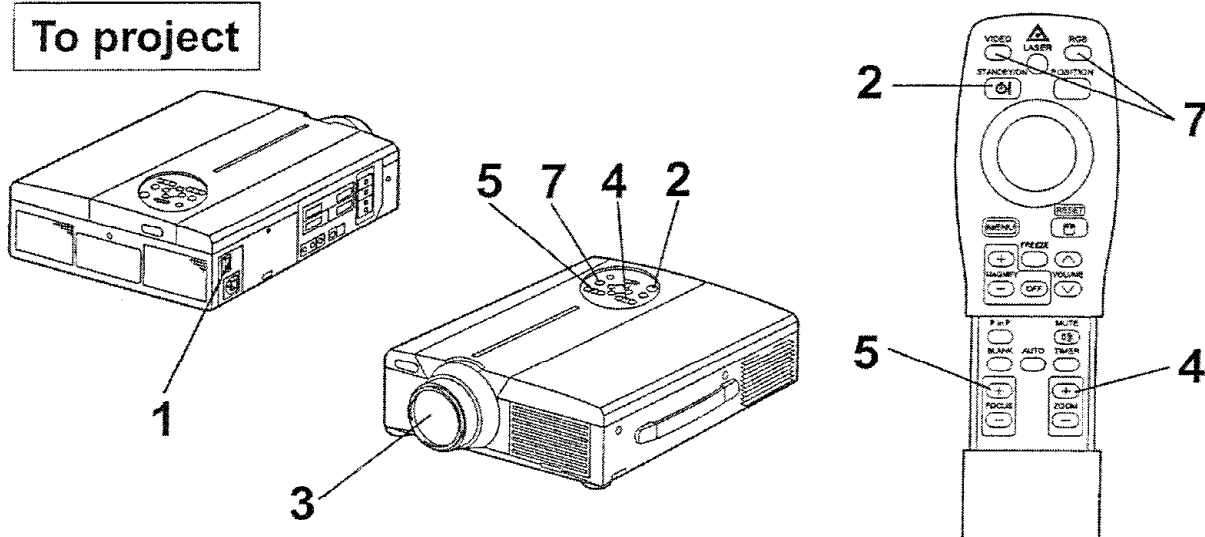

1 Turn on the main power switch of the projector [I: ON].

- The Power indicator lights orange.

2 Press the STANDBY / ON button.

- The Power indicator will blink green and then light green.
- The green blinking indicates warmup.

3 Remove the lens cap.

4 Use the ZOOM button to adjust the screen size.

5 Use the FOCUS button to adjust the focus.

(1) The display shown to the right will appear when the FOCUS button is pressed.

(2) Use the FOCUS button to adjust the focus until the image is sharp.

(3) The message "Focus" will disappear if any other button is pressed.

• (When there is no input signal, the Focus characters are not displayed when the input signal is outside the sync range.)

+++FOCUS+++

6 Turn on the power to the connected equipment.

Refer to page 31 concerning the connection of other equipment.

7 Press either the INPUT button of the projector or the VIDEO/RGB button of the remote control to select the signal to be projected on the screen.

Example on-screen display

RGB 1

The selected signal input channel will be displayed in the lower right part of the screen.

Basic operations (continued)

Turning off the power

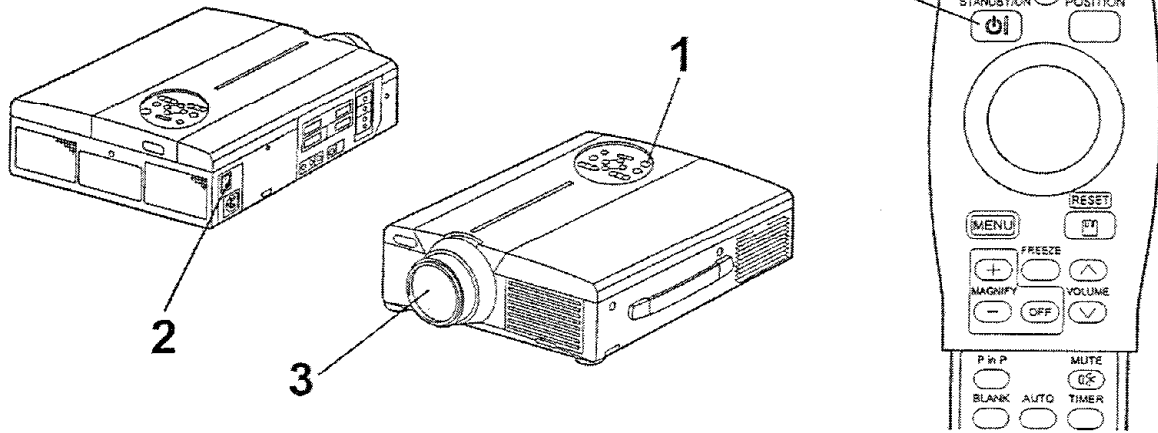

1 Press the **STANDBY/ON** button for approximately 1 sec.

- The Power indicator will blink orange, then the lamp will turn off. Approximately 1 sec. after that, the indicator will light orange.
- After the power is turned off, the lamp will be cooled for approximately 1 min. and the power cannot be turned off even by pressing the STANDBY/ON button.
- Press the STANDBY/ON button for at least 3 seconds to power off.

2 Turn off the main power switch of the projector [**○** : OFF].

3 Attach the lens cap.

Caution The fan will continue running for approximately 1 min. after the STANDBY/ON button is pressed. Do not turn off the main power switch while the lamp is on because this will shorten the service life of the lamp.

Plug & Play

This projector is VESA DDC 1 and DDC 2B compatible. Plug & play is possible by connecting to a computer that is VESA DDC (Display Data Channel) compatible to RGB 1.

(Plug & play is a system configured with peripheral equipment including a computer and display, and an operating system.

- Caution**
- Use the RGB cable included with this projector when using plug & play. With other cables, pins (12) - (15) are sometimes not connected (effective only for RGB1).
 - This device is recognized as a plug-and-play monitor. Use the standard Windows95/98 display drivers.
 - This function may not operate, depending on the personal computer used.
 - When the DDC function does not operate on a personal computer running Windows95/98, select the display type from Screen Priority. It is recommended that Super VGA 1024 x 768 (60-75Hz) be selected as the display type.
The DDC function will not operate when connected to a Macintosh.

Basic operations (continued)

Freeze function

This function is used to freeze the image being displayed.
(refer to page 10)

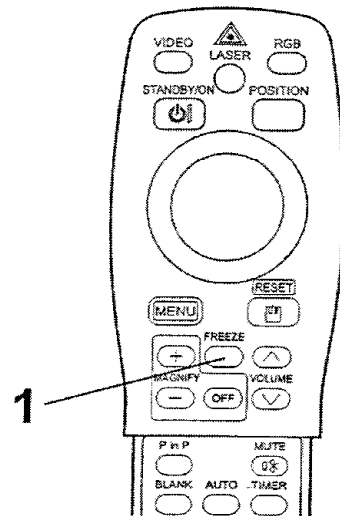

1 Press the FREEZE button.

- The image being displayed will freeze.
- The [||] mark appears in the lower right corner of the screen when the Freeze function is on.

Cancelling the FREEZE function

1 Press the FREEZE button.

- The FREEZE function will be cancelled.
- The [▶] mark will be displayed for approximately 3 sec. when the FREEZE function is cancelled.

- Caution**
- When there is no input signal, the Freeze function is not effective when the input signal is outside the sync range.
 - Pressing the FREEZE button alternately turns the freeze function on and off.
 - The FREEZE function will be cancelled when the input select button is pressed or the display mode of the PC being used for display is changed.
 - When a still image signal is input when the FREEZE function is on, make sure not to forget to cancel the FREEZE function.
 - FREEZE function will be cancelled after the operations such as "FOCUS +, -", "TIMER", "P in P", "AUTO", "BLANK", "VOLUME ^ v", "MENU", "MUTE" and "POSITION".

Basic operations (continued)

Magnify function

Part of an image can be displayed magnified.
(refer to page 10)

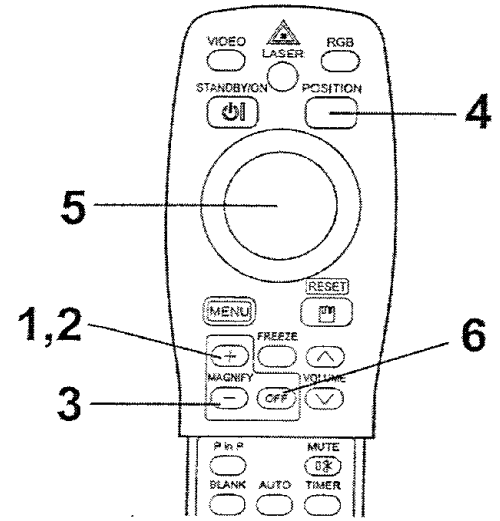

1 Press the MAGNIFY + button.

- The center part of the image will be displayed magnified approximately 2x.

Changing the magnification ratio

2 Press the MAGNIFY + button.

- When this button is pressed, the image will be displayed even larger.

3 Press the MAGNIFY – button.

- When this button is pressed, the image will be displayed even smaller.

Moving the display area

4 Press the POSITION button.

5 Press the DISK PAD up, down, left and right buttons.

- The magnified area will move in accordance with the button pressed.

Returning to normal display

6 Press the MAGNIFY OFF button.

Caution

- When there is no video signal input, Magnify is not effective when the video signal input is outside the sync range.
- The magnify function will be cancelled when the input select button is pressed or the display mode of the PC being used for display is changed.
- The Magnify function will be cancelled after the operations such as "AUTO", "KEYSTONE".

Adjustments and functions

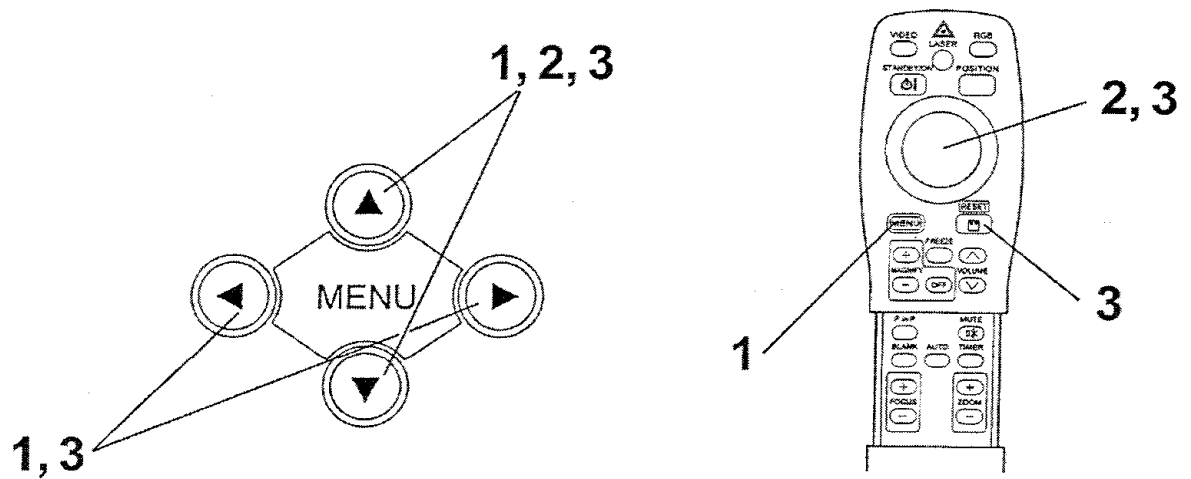

- 1** Press the MENU (▲▼◀▶) buttons of the projector or the MENU button of the remote control.

- The Menu screen will appear. (refer to page 18 - 21 for details.)

- 2** Press the MENU (▲▼◀▶) buttons of the projector or the DISK PAD button of the remote control to select the menu item to be adjusted. • The selected menu item will be displayed in orange.

- 3** Adjust the selected menu item with the MENU (▲▼◀▶) buttons of the projector or the DISK PAD button of the remote control.

- The selected menu item will be displayed in orange.

Returning to the initial settings

- Select the adjustment item to be returned to the initial settings.
- Press the RESET button.

Adjustments and functions (continued)

SET UP

Images and display positions can be adjusted from the SETUP menu.

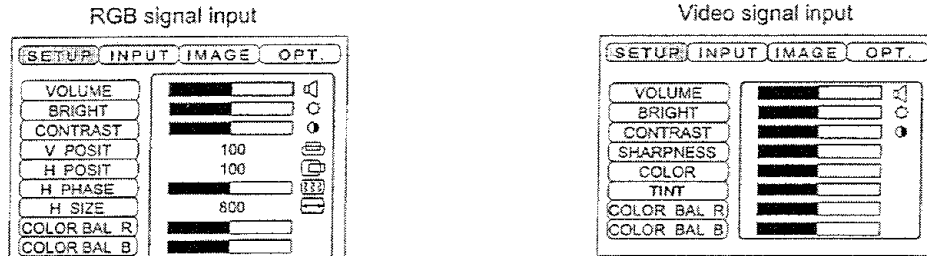

Adjustment item	Adjustment description
VOLUME	Volume decreases ← → Volume increases
BRIGHT (BRIGHTNESS)	Darker ← → Brighter
CONTRAST	Lower contrast ← → Stronger contrast
SHARPNESS	Softer image ← → Sharper image
COLOR	Less ← → More
TINT	Redder ← → Greener
V. POSIT (V. POSITION)	Moves the image up and down.
H. POSIT (H. POSITION)	Moves the image left and right.
H. PHASE	Eliminates blanking.
H. SIZE	Adjusts the horizontal size of the image.
COLOR BAL R (COLOR BALANCE Red)	Less red ← → More red
COLOR BAL B (COLOR BALANCE Blue)	Less blue ← → More blue

Using the SETUP Menu

Move the cursor to the item to be adjusted and move the MENU button of the projector or the DISK PAD button of the remote control to change the length of the bar display.

Caution

- The menu cannot be displayed while the initial screen ("No input is detected." or "Sync is out of range.") is being displayed.
- Tint cannot be adjusted with N-PAL, M-PAL, PAL or SECAM video signal input.
- Tint, color and sharpness cannot be adjusted with RGB signal input.
- V. POSIT, H. POSIT, H. PHASE and H. SIZE cannot be adjusted with video signal input.
- FREEZE function will be cancelled after the operation "Menu".
- Displaying the menu cancels freeze operations.

Adjustments and functions (continued)

INPUT

The INPUT menu is used to select RGB signal sync signal frequency of the monitor and the VIDEO signal.

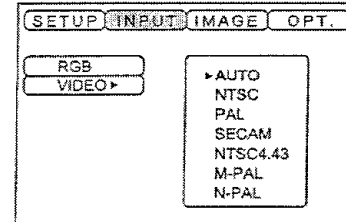
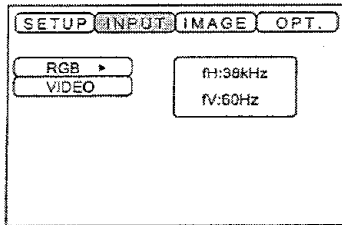

Adjustment item	Adjustment description
RGB	Displays the following RGB inputs fH: horizontal sync frequency fV: vertical sync frequency
VIDEO	Sets the video signal system. When the screen is unstable (no color) or rolls, select the mode that matches the input signal.

Adjustments and functions (continued)

IMAGE

H INVERT = Rear screen

Projection image inversion, etc., can be selected from the IMAGE menu.

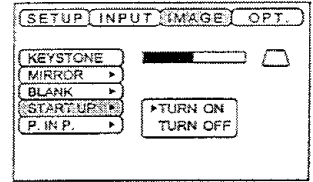
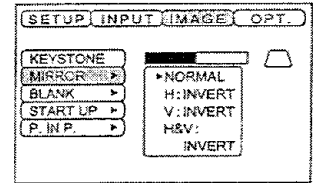
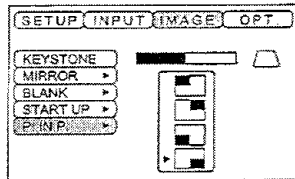
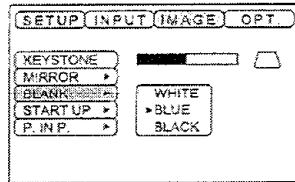
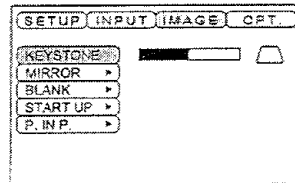
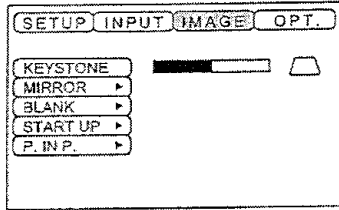

Adjustment item	Adjustment description
KEYSTONE	Reduces keystone distortion at the bottom ← → Reduces keystone distortion at the top
MIRROR	Sets vertical or horizontal inversion of the projected image. H: horizontal inversion only V: vertical inversion only H&V: both horizontal and vertical inversion.
BLANK	Sets the color to be used for blanking with BLANK ON or when there is no signal. Blanking is turned on, when there is no signal for approximately 5 min.
START UP	Opens and closes the initial settings screen during signal input at start up. When canceled, the background color will change to blue.
P in P	Selects the P in P sub screen display position.

Adjustments and functions (continued)

OPT

Communication functions, etc., can be set from the OPT menu.

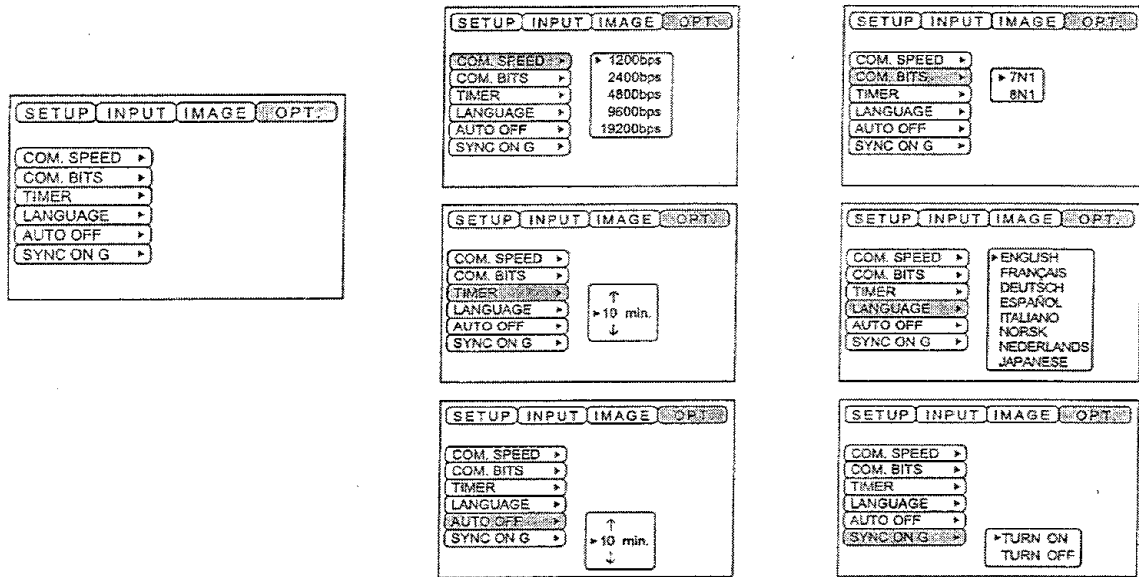

Adjustment item	Adjustment description
COM. SPEED	Sets the communication speed (5 steps).
COM. BITS	Sets the bit configuration for the communication data. 7N1...7 data bits, No parity, 1 stop bit. 8N1...8 data bits, No parity, 1 stop bit.
TIMER	Sets the timer display time (0 - 99) min.
LANGUAGE	Selects the menu screen language (English, French, German, Spanish, Italian, Norwegian, Dutch, Japanese).
AUTO OFF	Sets the time after which the power will be turned off (standby status) when there is no input signal. The settings are 1 - 99 min, 0 and None.
SYNC ON G	Sets the SYNC ON G feature on/off.

Connection to the video signal terminals

1. Input signals

S-VIDEO signal		Brightness signal	1.0V p-p, 75 Ω terminator
		Color signal	0.286V p-p (burst signal), 75 Ω terminator
VIDEO signal		1.0V p-p, 75 Ω terminator	
Audio signal	Input	200mV rms, 20k Ω or less (max. 3.0V p-p)	
	Output	0~200mVrms, 1k Ω	

2. Signal input jacks

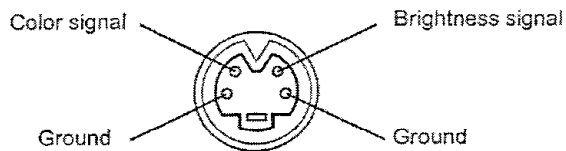

S-VIDEO input (mini DIN 4-pin)

Caution

The priority sequence of the video input jacks is as follows.

(1) S-VIDEO input jack (2) RCA jack input jack

When video signals are being projected, the audio input by the video is output to the audio output jack (RGB/VIDEO).

Connection to the RGB signal terminal

1. Input signals

Video signal		Analog, 0.7V p-p, 75 Ω terminator (positive polarity)
Horizontal sync signal		TTL level (positive/negative polarity)
Vertical sync signal		TTL level (positive/negative polarity)
Compound sync signal		TTL level
Audio signal	Input	200mV rms, 20k Ω or less (max. 3.0V p-p)
	Output	0~200mVrms, 1k Ω

2. Signal input jacks

Pin		Pin	
1	Video input (red)	9	N.C
2	Video input (green)	10	Ground
3	Video input (blue)	11	N.C
4	N.C	12	DDC jack (Display Data Channel)
5	N.C	13	Horizontal sync signal/compound sync signal
6	Ground (red)	14	Vertical sync signal
7	Ground (green)	15	DDC jack (Display Data Channel)
8	Ground (blue)		

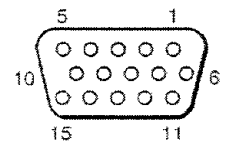

D-sub 15-pin shrink jack

Connection to the RGB signal terminal (continued)

3. Example of computer signal

Resolution H × V	fH (kHz)	fV (Hz)	Rating	Signal mode	Display mode	Note 1
640 × 400	24.8	56.4		NEC PC9800	Zoom in	
640 × 350	37.9	85.1	VESA	VGA-1	Zoom in	
640 × 400	37.9	85.1	VESA	VGA-2	Zoom in	
720 × 400	37.9	85.0	VESA	TEXT	Zoom in	
640 × 480	31.5	59.9	VESA	VGA-3	Zoom in	
640 × 480	35.0	66.7		Mac13"mode	Zoom in	SW 1 ON SW 2 ON
640 × 480	37.9	72.8	VESA	VGA-3(72Hz)	Zoom in	
640 × 480	37.5	75.0	VESA	VGA-3(75Hz)	Zoom in	
640 × 480	43.3	85.0	VESA	VGA-3(85Hz)	Zoom in	
800 × 600	35.2	56.3	VESA	SVGA(56Hz)	Zoom in	
800 × 600	37.9	60.3	VESA	SVGA(60Hz)	Zoom in	
800 × 600	48.1	72.2	VESA	SVGA(72Hz)	Zoom in	
800 × 600	46.9	75.0	VESA	SVGA(75Hz)	Zoom in	
800 × 600	53.7	85.1	VESA	SVGA(85Hz)	Zoom in	
832 × 624	49.7	74.5		Mac16"mode	Zoom in	SW 2 ON SW 4 ON
1024 × 768	48.4	60.0	VESA	XGA(60Hz)		
1024 × 768	56.5	70.1	VESA	XGA(70Hz)		
1024 × 768	60.0	75.0	VESA	XGA(75Hz)		
1024 × 768	67.8	85.0	VESA	XGA(85Hz)		
1152 × 864	67.5	75.0	VESA	SXGA(75Hz)	Zoom out	
1280 × 960	60.0	60.0	VESA	SXGA(60Hz)	Zoom out	
1280 × 1024	64.0	60.0	VESA	SXGA(60Hz)	Zoom out	
1280 × 1024	80.0	75.0	VESA	SXGA(75Hz)	Zoom out	

Note 1: The Mac adapter is required for some Mac modes.
 Projector is compatible with 13 inch mode and 16 inch mode.
 Mac 13" mode=switch 1 and switch 2 are ON.
 Mac 16" mode=switch 2 and switch 4 are ON.

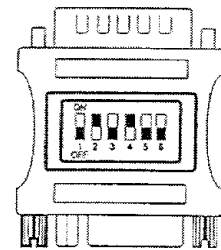

(Example 16 inch mode)

- Caution**
- Some computers may have multiple display screen modes. Use of some of these modes will not be possible with this projector.
 - Be sure to check jack type, signal level, timing and resolution before connecting this projector to a computer.
 - Depending on the input signal, full-size display may not be possible in some cases.

Connection to the RGB signal terminal (continued)

4. Initial set signals

The following signals are used for the initial settings.

The signal timing of some computer models may be different. In such case, refer to pages 17 and 18 and adjust the V.POSIT and H.POSIT of the menu.

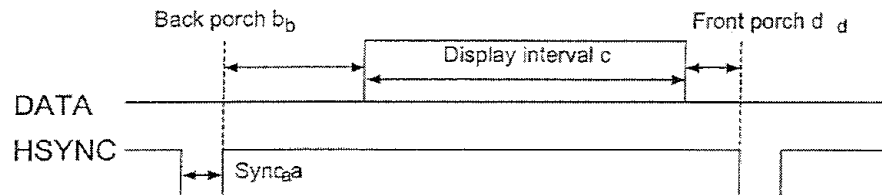

Computer/Signal	Horizontal signal timing (μ s)			
	a	b	c	d
VGA-1(85Hz)	2.0	3.0	20.3	1.0
VGA-2(85Hz)	2.0	3.0	20.3	1.0
PC-9800	3.0	3.8	30.4	3.0
TEXT	2.0	3.0	20.3	1.0
VGA-3	3.8	1.9	25.4	0.6
Mac 13"mode	2.1	3.2	21.2	2.1
VGA-3(72Hz)	1.3	3.8	20.3	1.0
VGA-3(75Hz)	2.0	3.8	20.3	0.5
VGA-3(85Hz)	1.6	2.2	17.8	1.6
SVGA(56Hz)	2.0	3.6	22.2	0.7
SVGA(60Hz)	3.2	2.2	20.0	1.0

Computer/Signal	Horizontal signal timing (μ s)			
	a	b	c	d
SVGA (72Hz)	2.4	1.3	16.0	1.1
SVGA (75Hz)	1.6	3.2	16.2	0.3
SVGA (85Hz)	1.1	2.7	14.2	0.6
Mac 16"mode	1.1	3.9	14.5	0.6
XGA (60Hz)	2.1	2.5	15.8	0.4
XGA (70Hz)	1.8	1.9	13.7	0.3
XGA (75Hz)	1.2	2.2	13.0	0.2
SXGA (1152 X 864, 75Hz)	1.2	2.4	10.7	0.6
SXGA (1280 X 960, 60Hz)	1.0	2.9	11.9	0.9
SXGA (1280 X 1024, 60Hz)	1.0	2.9	11.9	0.9
SXGA (1280 X 1024, 75Hz)	1.1	1.8	9.5	0.1

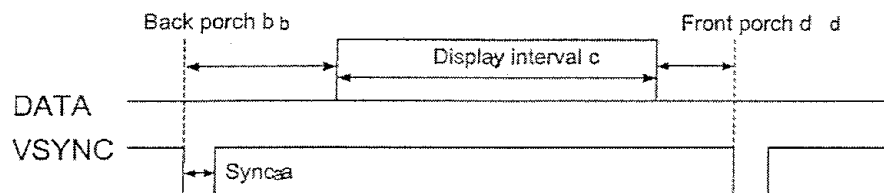

Computer/Signal	Vertical signal timing (lines)			
	a	b	c	d
VGA-1 (85Hz)	3	60	350	32
VGA-2 (85Hz)	3	41	400	1
PC-9800	8	25	400	7
TEXT	3	42	480	1
VGA-3	2	33	480	10
Mac 13"mode	3	39	480	3
VGA-3 (72Hz)	3	28	480	9
VGA-3 (75Hz)	3	16	480	1
VGA-3 (85Hz)	3	25	480	1
SVGA (56Hz)	2	22	600	1
SVGA (60Hz)	4	23	600	1

Computer/Signal	Vertical signal timing (lines)			
	a	b	c	d
SVGA (72Hz)	6	23	600	37
SVGA (75Hz)	3	21	600	1
SVGA (85Hz)	3	27	600	1
Mac 16"mode	3	39	624	1
XGA (60Hz)	6	29	768	3
XGA (70Hz)	6	29	768	3
XGA (75Hz)	3	28	768	1
SXGA (1152 X 864, 75Hz)	3	32	864	1
SXGA (1280 X 960, 60Hz)	3	36	960	1
SXGA (1280 X 1024, 60Hz)	3	38	1024	1
SXGA (1280 X 1024, 75Hz)	3	38	1024	1

Connecting the USB cable

1. Connect the projector and computer with a suitable commercially available cable. Disconnect the mouse cable from the projector.
2. Press the INPUT button of the projector or the RGB 1/2 button of the remote control and select the input where the computer is to be connected.
3. Start the mouse function.
4. Refer to page 10 concerning the remote control of mouse operations.
5. Varying the force with which the DISK PAD button is pressed varies the speed of mouse operation.

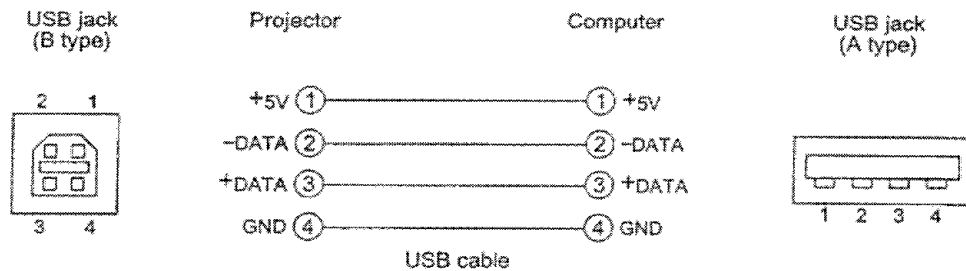

Caution

- Before making connections, read the instruction manual of the equipment to be connected.
- Use the optional USB cable to connect.
- Effective with USB only when the mouse is used.
- Do not use with any device other than a personal computer.
- When using with Windows 95, it is necessary to set so that USB can be used with version OSR 2.1 or higher. Depending on the kind or the version of the host controller, operation may not be possible in some cases.
- With some notebook computers that use a built-in pointing device such as a track ball, the built-in pointing device will have priority even if a mouse is connected and the mouse may not be selected.

In such case, disable the built-in pointing device and change the BIOS setting (system setup) so that an external mouse can be selected. (Check laptop users guide)

After changing the BIOS setting, perform the operations described in 1 - 3 above.

Refer to the computer hardware manual concerning the BIOS setting.

Also, some computers may not have a utility program to operate a mouse. Refer to the computer hardware manual.

Connection to the control signal terminal

1. Mouse functions

- (1) Turn off the main power switches of the projector and computer and connect the two units with the cable provided or an optional suitable commercially available cable. Disconnect the USB cable from the projector.
- (2) Turn on the main switch of the projector (the POWER indicator lamp will light green).
- (3) Press the INPUT button of the projector or the RGB button of the remote control and select the input where the computer is to be connected.
- (4) Turn on the computer power supply.
- (5) Start the mouse function.

If the mouse has not been started, reboot the computer (soft reboot or reboot buttons).

- (6) Refer to page 10 concerning remote control operation.
- (7) Varying the force with which the DISK PAD button is pressed varies the speed of mouse operation.

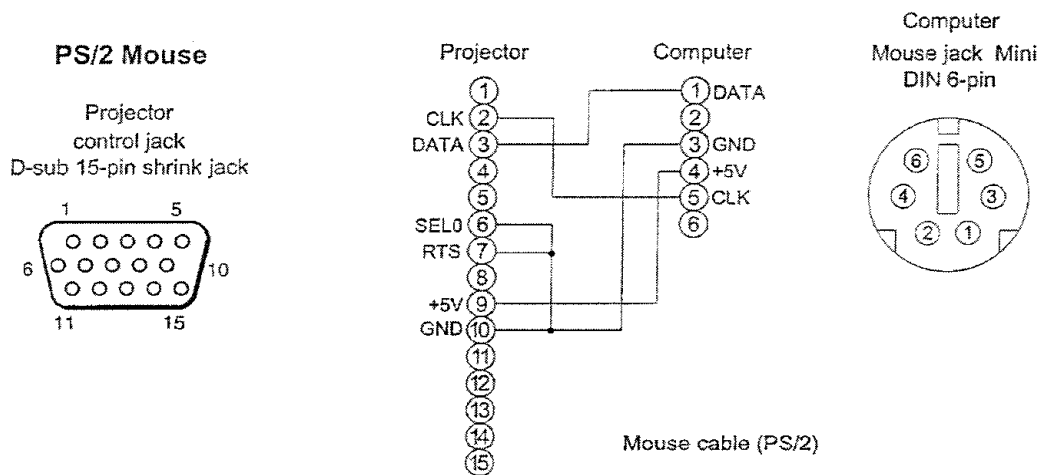

Use the mouse cable provided or a PS/2 mouse cable (for IBM and compatibles).
Cables for ADB mouse (Apple), bus mouse (NEC) and serial mouse are available as options.

Caution

- Before making connections, read the instruction manual of the equipment to be connected.
- Turn off the projector and computer power supplies before connecting.
Connecting the mouse cable with the computer power on can result in a malfunction.
Use the mouse cable provided or an optional mouse cable to make the connection.
- In the case of notebook type computers with a built-in pointing device such as a track ball, in some cases the built-in pointing device will have priority even if a mouse is connected and the mouse may not be selected.
In such case, disable the built-in pointing device and change the BIOS setting (system setup) so that an external mouse can be selected.
After changing the BIOS setting, perform the operations described in (1) - (3) above.
Refer to the computer hardware manual concerning the BIOS setting.
Also, some computers may not have a utility program to operate a mouse. Refer to the computer hardware manual.

Connection to the control signal terminal (continued)

CONTROL signal jack

Pin no.	RS-232C	Mouse		
		PS/2	ADB	Serial
1				YB
2		CLK		
3		DATA	DATA	
4				
5				
6	SELO	SELO		SELO
7	RTS	RTS	RTS	RTS
8				
9		+5V	+5V	
10	GND	GND	GND	GND
11				
12				
13	RD			
14	TD			TD
15				

ADB (Mac) mouse

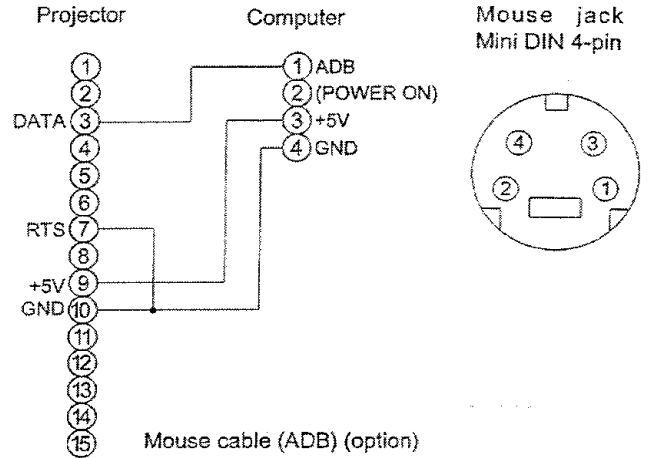

Serial mouse

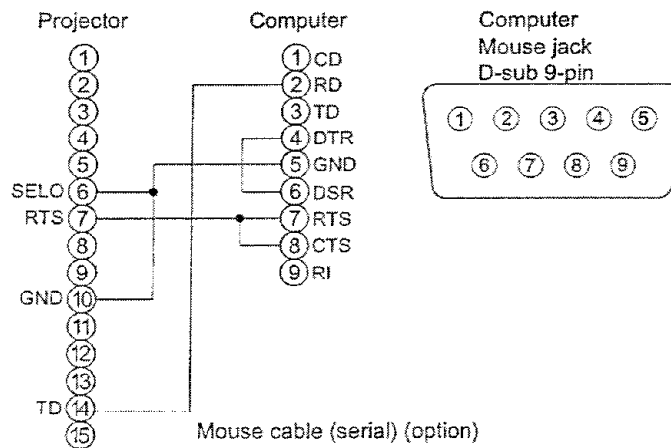

Connection to the control signal terminal (continued)

2. RS232C communication

- (1) Turn off the projector and computer power supplies and connect with the RS232C cable.
- (2) Turn on the computer power supply and, after the computer has started up, turn on the projector power supply.
- (3) Refer to page 21 and set the communication speed and the number of communication bits.
- (4) Start RS232C communication.

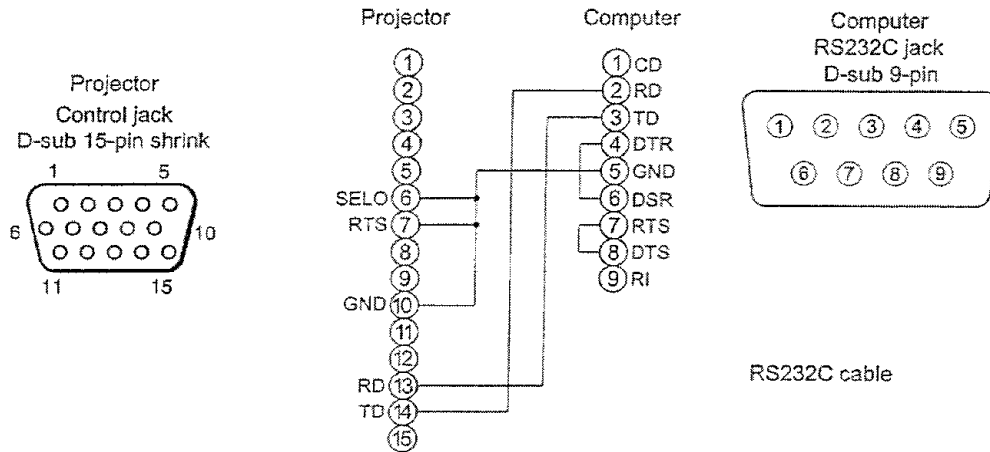

Command	Projector→computer		Computer→projector					
	Response code		Inquiry code		Setting code		Default setting code	
	1st	2nd data	1st	2nd	1st	2nd data	1st	2nd
MOUSE	11h	05h +1	20h	05h	31h	05h +1	40h	05h
COMMUNICATE	11h	06h +1	20h	06h	31h	06h +1	40h	06h
POWER	11h	11h +1	20h	11h	31h	11h +1	---	---
ZOOM	11h	12h +1	---	---	31h	12h +1	---	---
FOCUS	11h	13h +1	---	---	31h	13h +1	---	---
MIRROR	11h	14h +1	20h	14h	31h	14h +1	40h	14h
INPUT	11h	21h +1	20h	21h	31h	21h +1	40h	21h
(VIDEO)SYSTEM	12h	22h +2	20h	22h	32h	22h +2	40h	22h
VOLUME	11h	23h +1	20h	23h	31h	23h +1	40h	23h
MUTE	11h	24h +1	20h	24h	31h	24h +1	40h	24h
BRIGHT	13h	31h +3	20h	31h	33h	31h +3	40h	31h
CONTRAST	13h	32h +3	20h	32h	33h	32h +3	40h	32h
COLOR	13h	33h +3	20h	33h	33h	33h +3	40h	33h
TINT	13h	34h +3	20h	34h	33h	34h +3	40h	34h
SHARPNESS	13h	35h +3	20h	35h	33h	35h +3	40h	35h
H.PHASE	13h	37h +3	20h	37h	33h	37h +3	40h	37h
H.POSIT	14h	38h +4	---	---	34h	38h +4	40h	38h
H.SIZE	14h	36h +4	---	---	34h	36h +4	40h	36h
V.POSIT	14h	3Ah +4	---	---	34h	3Ah +4	40h	3Ah
COLOR BALANCE R	13h	3Bh +3	20h	3Bh	33h	3Bh +3	40h	3Bh
COLOR BALANCE B	13h	3Dh +3	20h	3Dh	33h	3Dh +3	40h	3Dh
AUTO ADJUST	11h	3Ch +1	20h	3Ch	31h	3Ch +1	40h	3Ch
BLANK	11h	41h +1	20h	41h	31h	41h +1	40h	41h
MAGNIFY	11h	15h +1	20h	15h	31h	15h +1	40h	15h
FREEZE	11h	16h +1	20h	16h	31h	16h +1	40h	16h

Connection to the control signal terminal (continued)

Command data chart

Item	Data code
MOUSE	00h=disable mouse function, 01 ~ 7Fh=start mouse function
COMMUNICATE	0Xh=8N1, 1Xh=7N1 X0h=1200bps, X1h=2400bps, X2h=4800bps, X3h=9600bps, X4h=19200bps
POWER	3Eh=power off (standby status), 3Fh=power on
ZOOM	01 ~ 3Fh=Zoom +, 41 ~ 7Fh=Zoom -
FOCUS	01 ~ 3Fh=Focus +, 41 ~ 7Fh=Focus -
MIRROR	00h=Normal, 01h=H : Invert, 02h=V : Invert, 03h=H & V : Invert
INPUT	11h=VIDEO, 21h=RGB1, 22h=RGB2
SYSTEM (VIDEO)	00h 00h=Auto, 00h 01h=NTSC, 00h 04h=NTSC4.43 00h 02h=PAL, 00h 03h=SECAM, 00h 05h=M-PAL, 00h 06h=N-PAL
VOLUME	00h (low volume) ~ 24h (high volume)
MUTE	00h=mute off, 01h=mute on
BRIGHT	00h 00h 00h (dark) ~ 00h 00h 24h (bright)
CONTRAST	00h 00h 00h (low) ~ 00h 00h 24h (strong)
COLOR	00h 00h 00h (pale) ~ 00h 00h 24h (dense)
TINT	00h 00h 00h (reddish) ~ 00h 00h 24h (greenish)
SHARPNESS	00h 00h 00h (soft) ~ 00h 00h 24h (sharp)
H.PHASE	00h 00h 00h ~ 00h 00h 24h
H.POSIT	00h 00h 00h 01h (Right) moves one step 00h 00h 00h 7Fh (Left) moves one step
H.SIZE	00h 00h 00h 01h (Large) moves two step 00h 00h 00h 7Fh (Small) moves two step
V.POSIT	00h 00h 00h 01h (Up) moves one step 00h 00h 00h 7Fh (Down) moves one step
COLOR BALANCE R	00h 00h 00h (Light red) ~ 00h 00h 24h (Dark red)
COLOR BALANCE B	00h 00h 00h (Light blue) ~ 00h 00h 24h (Dark blue)
AUTO ADJUST	00h (AUTO ADJUST (Play))
BLANK	0Xh=blanking off, 1Xh=blanking on X=8 Black, X=9 Blue, X=F White
MAGNIFY	00h=normal display, 01h=zoom Magnify display or Magnify ratio up. 7Fh=zoom ratio down
FREEZE	00h=normal display, 01h=still image display

The command code configuration consists of a 2-byte command and the following data.

- The first byte of a command indicates the command type with 3 bits on the MSB side and the data length with 4 bits on the LSB side.

Projector - computer

'0xH' : Error code

'1xH' : response code

'70H' : frame error code

'x' indicates the data length (example: x=2 means a 2-byte command).

Computer - projector

'2xH' : inquiry code

'3xH' : setting code

'4xH' : default setting code

- The second byte of a command indicates the command contents.

Connection to the control signal terminal (continued)

Requesting projector status

- (1) Send the request code '20H' + 'yyH' from the computer to the projector.
- (2) The projector returns the response code '1xH' + 'yyH' + data to the computer.

Changing the projector settings

- (1) Send the setting code '3xH' + 'yyH' + data from the computer to the projector.
- (2) The projector changes the setting based on the above setting code.
- (3) The projector returns the response code '1xH' + 'yyH' + data to the computer.

Caution The response data in (3) above need not match the setting data in (1). For example, when the projector cannot set the setting data in (1), the projector may set the closest value. That value will be used as the response data in (3). Or else the projector will return the error code '0xH' + 'yyH' + data.

Using the projector default settings

- (1) The computer sends the default setting code '40H' + 'yyH' to the projector.
- (2) The projector changes the specified setting to the default value.
- (3) The projector returns the default value with the response code '1xH' + 'yyH' + data.

When a command sent by the projector cannot be understood by the computer

- (1) The computer sends the command code '3xH', '4xH' or '4xH' + 'yyH' + data to the projector.
- (2) When the command sent by the projector cannot be understood, the error command '00H' + 'yyH' is returned by the computer.

When data sent by the projector cannot be understood

- (1) The computer sends the command code '3xH', '4xH' or '4xH' + 'yyH' + data to the projector.
- (2) When the command sent by the projector cannot be understood, the error code '0xH' + 'yyH' + data is returned.

When the data length is greater than indicated by the data length code, the projector will ignore the excess data code. Conversely, when the data length is shorter than indicated by the data length code, an error code will be returned to the projector.

When a frame error occurs

Repeats 10 times per second until there is some sort of response to the error code 70H + 70H.

When the interval between bytes in one command is 500ms or greater

When a command or data is not sent within 500ms after the command code '2xH', '3xH' or '4xH' is sent by the computer, the error command '70H' + '70H' will be returned as soon as the 500ms elapses. After this, if there is no response within 1 sec., a frame error will occur.

Caution

- Operation cannot be guaranteed when the projector receives an undefined command or data.
- Provide an interval of at least 40ms between the response code and any other code.

Example of system setup

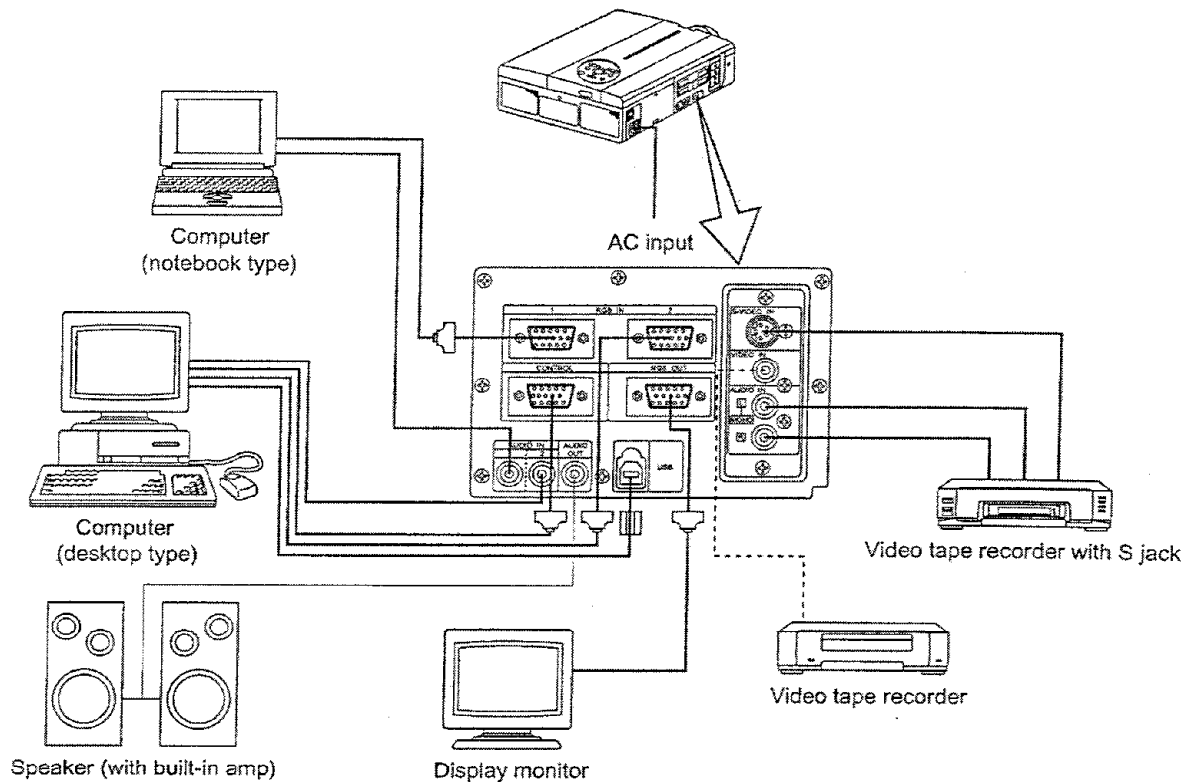

Caution Turn power off to all devices before connecting.
Refer to the instruction manual of each device before connecting.

Cleaning the Air filter

Clean the air filter about every 100 hours .

- 1** Turn off the **MAIN POWER** switch of the projector and pull out the power cord.
- 2** Remove the front air filter.

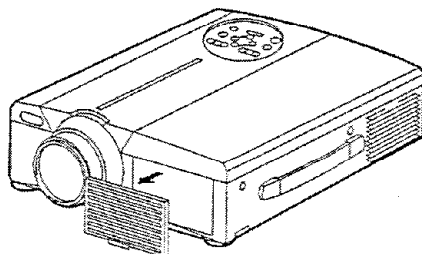

Cleaning the Air filter (continued)

3 Cleaning the air filter with a vacuum cleaner

4 Installing the air filter

Caution When the air filter becomes clogged with dust, etc., the projector power may turn off to prevent the internal heat level rising. (The lamp indicator color changes to red.) Do not operate the projector with the air filter removed. (If used with the air filter removed, dust can enter the LCD panel and produce an adverse effect on image quality.)

Lamp

The light source lamp has a service life.

When used for an extended time, the images may become darker and the colors may deteriorate.

A malfunction could occur if the projector is used in this condition, so replace the lamp with a new one.

The following indicator or a message which appears when the power is turned on will indicate when the lamp should be replaced.

At such time, it is necessary to replace the lamp with a new one. For lamp replacement, please contact your dealer or service company.

Caution Even when the lamp is at a high temperature, the power to the projector may cut off to prevent an excessive temperature increase inside the projector. (The POWER indicator turns off.) Turn off the MAIN POWER switch, wait for some 20 minutes and turn on the MAIN POWER switch again. If the projector is not recovered after turning on the MAIN POWER switch, please contact your dealer or service company.

Message table

Screen displays

The following messages are displayed on the screen.

CHANGE THE LAMP*CALL A MAINTENANCE PERSON*	The total lamp usage time is nearing the service life of the lamp. Replace with a new lamp. The lamp will turn off automatically when the lamp replacement time has been exceeded. *1
"CHANGE THE LAMP" "CALL A MAINTENANCE PERSON" "THE POWER WILL TURN OFF AFTER * hr."	The total lamp time is nearing the lamp replacement time. After (*) hours, the lamp will turn off. Quickly replace with a new lamp. *1 *Indicates the number of hours until the lamp turns off automatically.
Blinking of "CHANGE THE LAMP"	The total lamp time has exceeded the replacement time. The indicator will blink for approximately 10 min. and then turn off automatically. Replace with a new lamp.
NO INPUT IS DETECTED	There is no signal input (refer to pages 22, 23).
SYNC IS OUT OF RANGE	The current horizontal or vertical frequency cannot be used by this projector (refer to pages 23, 24).

*1 This display will disappear after 3min. but will reappear when the power is turned on again.

Message table (continued)

Indicators

The POWER indicator, LAMP indicator and TEMP indicator light or blink in the following cases.

POWER indicator	LAMP indicator	TEMP indicator	Status	Processing
Lights orange	Turns off	Turns off	Standby status	_____
Flashes green	Turns off	Turns off	Warming up	_____
Lights green	Turns off	Turns off	Operation status *1	_____
Flashes orange	Turns off	Turns off	Cool down	_____
Lights red	Lights red	Turns off	The lamp does not light. *2 The interior is too hot.	Wait some time (approx. 20 min.) before turning the power on again. Clean the air filter before turning the power on. If the indicator still lights, contact your dealer.
Lights red	Flashes red	Turns off	A lamp has not been inserted or the lamp cover is missing.	Contact your dealer.
Lights red	Turns off	Flashes red	The cooling fan is not operating.	Contact your dealer.
Flashes red	Flashes red	Turns off	The total lamp time has exceeded the replacement time.	Contact your dealer.

When the LAMP or TEMP indicator lights or flashes, turn off the MAIN POWER switch before proceeding. If the problem still persists, contact your dealer or service company.

*1: When the cooling fan is stopped and the interior becomes overheated, the power will turn off automatically to allow cooling (the indicator will turn off). In such cases, turn off the projector power, allow the set to cool and then turn the projector power on again. The lamp will then light. If the lamp does not light, contact your dealer or service company.

*2: In some cases, when the air holes becomes blocked and the interior temperature rises, the lamp will be turned off for protection and the LAMP indicator will flash red. In such cases, turn off the MAIN POWER switch, allow the set to cool (for approx. 20 min.) and then turn the power on again.

Troubleshooting

Before requesting repair, check in accordance with the following chart. If the situation cannot be corrected, then contact your dealer.

Symptom	Possible cause	Remedy	Page
The power is not turned on.	•The main power switch is not turned on. •The power cord is disconnected.	•Turn on the main power switch. •Plug the power cord into an AC power outlet.	P.13 P.9
No video or audio.	•The input is not correctly set. •No signal input.	•Use the projector or remote control to set. •Connect correctly.	P.8,10, 13,19 P.9,31
Video is present but no audio.	•The projector is not correctly connected. •The volume is set to minimum. •Mute is turned on. •Audio is switched to RGB when P in P is on.	•Connect correctly. •Press VOLUME + on the remote control or display the menu screen and adjust the volume. •Press the MUTE button. •Displays the Volume bar and switches the Audio input.	P.9,31 P.10,18 P.8,10 P.10
Audio is present but no video.	•The projector is not correctly connected. •The brightness adjustment knob is rotated fully clockwise. •The lens cap is still on.	•Connect correctly. •Select BRIGHT with the MENU button and then press the (▶) key. •Remove the lens cap.	P.9,31, P.17 P.13
Colors are pale and color matching is poor.	Color density and color matching are not correctly adjusted.	Adjust the video.	P.18
Images are dark.	•Brightness and contrast are not correctly adjusted. •The lamp is nearing the end of its service life.	•Adjust the video. •Replace with a new lamp.	P.18 P.32
Video is blurred.	Focus or H PHASE is out of adjustment.	Adjust the focus or H PHASE.	P.13,18
The LAMP indicator lights red.	Lamp failure.	Wait approximately 20 min. and then turn the power on again.	P.33
	Internal overheating.	•Make sure the ventilation openings are not blocked. •Clean the air filter. •Lower the ambient temperature to 35 degrees C or less.	P.31,32

Specifications

· These specifications are subject to change without notice.

Product name		Desktop Projector
Model		DP6850/DP6850+
Display method		Three liquid crystal panels, three primary color system.
Liquid crystal panel	Panel size	3.3 cm (1.3 Inch)
	Drive system	TFT active matrix
	Number of pixels	786,432 pixels (1,024 horizontal × 768 vertical)
Lens		Zoom lens F=1.7~2.3 f=49~64mm
Lamp		190w UHB
Speaker		1.2W + 1.2W (Stereo)
Power supply		AC100 ~ 120V, 3.7A / AC220 ~ 240V, 1.5A.
Power consumption		320W
Operating temperature range		0 ~ 35°C
Size		289mm(W) × 124mm (H) × 345mm (D), 11" (W) × 5" (H) × 14" (D)
Weight (mass)		6kg ,13 lbs
VIDEO signal input jacks		S VIDEO: mini DIN 4-pin jack VIDEO: RCA jack AUDIO: RCA jack
RGB signal input/output jacks		RGB signals: D-sub 15-pin shrink jack Audio: stereo mini-jack
CONTROL signal jack		D-sub 15-pin shrink jack
USB jack		B type

Resolution	Horizontal 500 TV lines
Compatibility	NTSC, PAL, SECAM, NTSC4.43, M-PAL, N-PAL
H. Sync. Range	fH; 25~80kHz
V. Sync. Range	fV; 56~120Hz
Keystone correction	OPTICAL; Fixed 20:1 upward shift, Normal at +10.8°~8.2° projection angle DIGITAL; ±10%
Noise rating	40dB

Specifications (continued)

Dimensional Diagram

Unit: inches

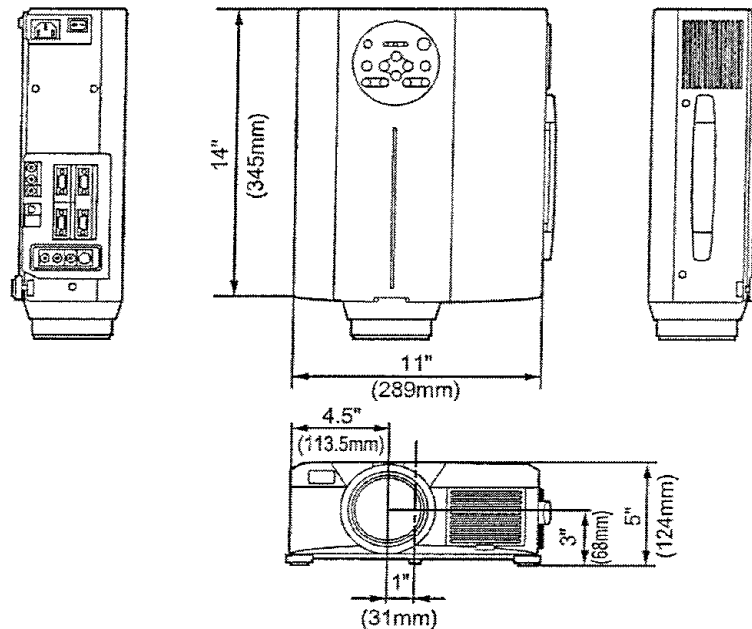

About the warranty and after-service

About the warranty

A warranty is provided for this product. Fill in the necessary items and store in a safe place.

About after-service

When a problem occurs, please check first using the Troubleshooting Chart provided in this instruction manual. If the problem still persists, contact your dealer or service company.

About repairs during the warranty period

Repairs will be made as described in the warranty.
For details, please read the warranty.

About the warranty and after-service (continued)

Limited Warranty

Proxima Corp. ("Proxima") warrants that each Desktop Projector DP6850/DP6850+ ("Product") projector purchased from Proxima Corp. is free from defects in materials and workmanship under normal use during the warranty period said warranty shall commence on the day of purchase by the End-User and continue for a period of two (2) years.

To exercise the End-User's rights under this warranty, the Product must be returned at the End-User's expense, to Proxima Corporation or to any authorized Proxima Corp. service center. The returned product must be accompanied by (i) the End-User's sales receipt or invoice that shows the date of sale, product type and dealer's name, and, when returned to Proxima Corporation, (ii) a return authorization number, issued by Proxima Corporation that is clearly displayed on the outside of the shipping carton. The Warranty extends only to the original End-User purchase and is not transferable.

EXCLUSIVE REMEDY

During the Warranty Period, Proxima Corp. will, at no additional charge, repair or replace defective parts or, at the option of Proxima Corporation, replace the entire unit. Proxima Corporation shall have no other obligation, and repair or replacement shall be the End-User's exclusive remedy for any defect in the Product.

WARRANTY LIMITATION AND EXCLUSION

This Limited warranty does not extend to any Product that has been damaged due to accident, unauthorized modifications, tampering, abuse, misuse, alterations, unusual physical or electrical stress, or to any Product that has been serviced by other than Proxima Corporation or its authorized agents or which has been used in any manner other than from ordinary use in the application for which it was intended.

THE FOREGOING WARRANTY IS EXPRESSLY IN LIEU OF ANY OTHER EXPRESS OR IMPLIED WARRANTIES, INCLUDING, WITHOUT LIMITATION, WARRANTIES OF MERCHANTABILITY OR FITNESS FOR A PARTICULAR PURPOSE. TO THE EXTENT NOT PROHIBITED BY LAW, ALL STATUTORY WARRANTIES ARE HEREBY WAIVED AND EXCLUDED FROM THIS LIMITED WARRANTY. PROXIMA CORPORATION EXPRESSLY DISCLAIMS ALL WARRANTIES NOT STATED IN THE LIMITED WARRANTY.

LIMITATION OF LIABILITY

It is understood and agreed that the liability of Proxima Corporation, whether in contract, in tort, under any warranty, in negligence or otherwise shall not exceed the return of the amount of the purchase price paid by the End-User and under no circumstances shall Proxima Corporation be liable for special, indirect or consequential damages. No action, regardless of form, arising out of the agreement to purchase the Product may be brought by the End-User more than one year after the cause of the action has accrued.